

Abstract

The categorization of the many musical and literary works inspired by the Faust legend is based on their two possible conclusions: Faust ends up in Hell or is redeemed and attains Heaven. Busoni's work is often categorized in terms of the redemptive form. I will analyze a third possibility: during the last part of the nineteenth century, philosophers conceptualized that man's feelings of unhappiness came from his confinement into an eternal recurrence and that life doesn't end with the death.

Scholars tend to ignore the links between *Doktor Faust* and these philosophical thoughts because of Busoni's explicit denial of such intentions. And yet Busoni wrote that an opera is the highest form of artistic expression, where music gives words to the unspoken. Therefore I will argue that Busoni characterizes *Doktor Faust* as a hybridization of the new philosophical theories with literature and music. Busoni's depiction of the main character in this opera may not be intentional, but the composer summed up all the qualities of Nietzsche's *Übermensch*, D'Annunzio's *Superuomo*, and Pascoli's *fanciullino* in Faust.

Faust discovers his own transcendent power, which is independent from the material universe and yet belongs to nature's laws that are beyond God and the evil. *Doktor Faust's* attainment of immortality does not pray for divine redemption and wins out over everything: in this opera, Faust is neither redeemed nor damned. Faust becomes aware that death is nothing but the means that lead to rebirth: "ich, Faust, ein ewiger Wille".

Transcendence and immortality in Busoni's *Doktor Faust*

Antonella Di Giulio

... das gibt den Sinn dem fortgesetzten Steigen, zum vollen Kreise
schließt sich dann der Reigen.
(... this gives meaning to the continued rise, the round closes then in a
full circle).

Busoni, *Doktor Faust*, front cover [1984]

The several musical and literary works inspired by the Faust legend are generally categorized according to their two possible conclusions: Faust either ends up in Hell or is redeemed and attains Heaven. Particularly in early tales, the figure of Faust is irrevocably corrupted and his soul cannot be forgiven. For example, in Marlowe's *The Tragical History of Doctor Faustus*, published in 1604, the final scene shows Doktor Faustus warning the scholars that he is damned and Mephistopheles is coming to take him to Hell. This prediction remains unfulfilled and the finale, left open, allows for multiple outcomes. Goethe's version of the legend, written two centuries later, includes both conclusions: in *Faust: The First Part of the Tragedy* the story ends in misfortune for Faust, while in *Faust: The Second Part of the Tragedy* the protagonist attains redemption.¹ Busoni's *Doktor Faust* is often categorized in terms of the redemptive form. And yet this categorization seems rather unpersuasive, especially since Busoni's intentions appear to be much more insightful and astonishingly intriguing in the final scene of this opera.

¹ Successively, in 1846, in *La Damnation de Faust* Berlioz placed Faust in Hell, while in Gounod's *Faust* and Boito's *Mefistofele*, the Devil is turned away by an archangel or a celestial choir.

Genesis of the plot

Pacts with dark forces and the search for immortality were topics that had fascinated Busoni for years.² At first Busoni's intention was to write an opera based on Leonardo da Vinci, the "Italian Faust", in collaboration with Gabriele D'Annunzio. However, D'Annunzio was not convinced that an opera based on a sterile character like Leonardo Da Vinci would have been valuable.³ For Busoni's opera, D'Annunzio suggested a plot inspired by a character like Faust, intended as a symbolic representation of the *Superuomo*.⁴ After the project with D'Annunzio was abandoned, Busoni continued in his search of a subject for the "perfect opera" [Beaumont 1985].

Faust, as a character, was tempting, but this choice would have surely drawn comparisons with Goethe's work. After attending a performance of the *Faust* puppet-play in a Berliner theatre, Busoni decided to base *Doktor Faust's* plot on the *Historia vnd Geschicht Doctor Johannis Faustj*, published in 1587. In Busoni's libretto, which was published in 1914, the Italian composer mainly followed the puppet-play in its original version, re-elaborating a few details. On May 14, 1920 Busoni wrote to his fellow composer, Gisella Selden-Goth, about some of the changes he undertook in *Doktor Faust*:

I follow the puppet-play... fairly literally in the two prologues and in the Parma scene. ... I take the Duchess as the point of departure for my own thought-process, hence diverging from the Puppet play. The child becomes a symbol that causes and permits an almost reconciliatory solution, transcending the framework of the play [Chamness 2001, 35].

In the same letter he also explains that the child «is the starting point

² In *Fantastic Tales*, composed in 1880, one of the pieces was inspired by a story dating to the early nineteenth century written by William Hauff, *The Cave of Steenfohl*, where the fisherman sells his soul to the Devil. In the sketches for the opera *Ahasver*, Ahasuerus (*the Wandering Jew*, main character) was sentenced to immortality [Beaumont 1985, 314].

³ Busoni wrote about his encounters with D'Annunzio in Paris in a letter to his wife on June 1913 [Ley 1938, 225].

⁴ Busoni suggested an opera on Leonardo Da Vinci, depicted as the "Italian Faust" [Ley 1938, 229].

for the spiritual survival of the individual», that he has no philosophical intention and that the mystical ending was written later than the rest of the libretto «as a result of Rubiner's criticism». Ludwig Rubiner, German expressionist and Busoni's friend, had developed utopian theories about a “New Man” in an eternist prospective, condemning the materialism of modern society [Rubiner 2013].⁵

Unfortunately Busoni died in 1924 and the opera was left unfinished.⁶ The Italian composer was only able to compose the music up to the opening of the final scene. The very scene in which various philosophical currents of Busoni's time are intertwined in a living will: God is dead, and man, through a child, will attain the immortality and win God and the Devil over through his will to power.

Transformation

The last scene composed by Busoni shows the Duchess entrusting her son to Faust, his father. Carrying the baby in his arms, Faust tries to look for redemption, but a soldier precludes him entry into the church. In the meanwhile a choir sings a prayer to God, who is not always God of mercy, but also a God of vengeance and punishment. The music composed by Busoni for this scene ends on Faust's words: «Hinweg, hinweg, ich habe zu beten. Zergehe, du Höllenspuk, noch bin ich Herr!» [*Away, away, I have to pray. Go away, you Hellish ghost, I am still the Lord!*]. This last verse, and in particular the last part of it, represents both the climax of the entire opera and a turning point in

⁵ One recurrent theme in his writing is man, with his spiritual needs, and a whole theoretical conception about the future of society, seen as the utmost human responsibility in ethical values. Rubiner was inspired in his program by the philosopher Martin Buber (1878-1965), who had an ideological position based on the absolute value of the spirit and the denial of the soul: «Die Welt könnte voller Wunder sein. Aber die Seele hält uns von ihnen zurück. [...] Das Denken tut das Wunder. Sonderlich die Seele wartet auf das Wunder. Die Seele wartet auf das Wunder, weil sie von ihm eine Bereicherung erhofft» [Rubiner 2013, 186].

⁶ For the finale of this opera there are two versions: the first one was written right after the composer's death in 1926 by Busoni's assistant Philip Jarnach, who took some of the themes of previous scenes and concluded the opera in a kind of Wagnerian style, which probably is not what Busoni was actually had in mind. The other version was written in 1984 by Anthony Beaumont, who based his version on some of Busoni's sketches that Jarnach had donated to a library.

Faust's character: it is an extraordinary moment where an important transformation takes place in the protagonist, who transitions from wanting to pray to God for his salvation to the affirmation of his "I". The episode can be subdivided into three main sections: in the first section Faust tries to head for the Church singing a solo, in the second section the choir tells him that God will not listen to his prayers while Faust interrupts the melody with a «Lass mich» [let me], in the third section Faust reaffirms his power to will (Fig. 1).

I Section

FAUST seeks redemption

II Section

The CHOIR sings about a God of vengeance and punishment. FAUST interrupt with "Lass mich"

III Section

FAUST reaffirms his power to will

Figure 1. Subdivision of the final scene composed by Busoni

The first motive appearing in this scene recalls a previous one sung by Faust shortly before he received the child from the Duchess. While in the previous scene the harmonic structure accompanying the motive was preceded by a repeated tonic on C minor chord, the harmony in the final episode returns to Eb Major on a dominant pedal, despite the use of the same pitches in the melody. The difference between the motives in the two scenes could be interpreted as being represented by the absence/presence of the child on the stage. In the episode in C minor Faust had lost hope: since he knows that he has been sentenced to death because of his pact with the Devil, he sings in an *Andante* tempo, with a homogeneous rhythm and on a static tonic chord. In the episode in the major key, Faust is aware about the existence of his progeny: he sees the possibility to earn a last chance to save his soul. Therefore he sings in tempo *Allegro* and also the rhythm reflects Faust's excitement. The melody, structured as an overall ascending scale, starts on the leading tone of the main key, ends on a dominant chord, and then resolves on the tonic: this child becomes the leading tone of life and therefore symbolizes hope in a plausible future (Fig. 2).

Figure 2. Motive from a previous scene versus the same motive in the last scene with the music composed by Busoni

The child: intuition or final metamorphosis?

In *Il fanciullino* Giovanni Pascoli had used a child as the symbolic representation of someone capable of recognizing the relationships between that which escapes our senses and our intellect through intuition [Pascoli 1982]. He describes the poet as he who discovers the truth while listening to the voice of the child inside him. Pascoli's metaphor is an inner condition, a pure and naive curiosity towards nature, which is independent from age. While Pascoli interprets the child as he who knows how to observe the world poetically, Busoni, who also uses the child as a symbol, transforms a hopeless Faust into an individual who is finding a glimmer of hope in the innocence of childhood through his son. In this metaphor Busoni goes further than Pascoli, as Faust's intuitions not only discover nature, but also the truth beyond it.

Through this pure intuition, Faust becomes conscious of a profound knowledge that will completely transform his actions on the stage during the last scene, in which he is wandering in front of the Church. In the first section of this episode the overall ascending contour ends on the word «God» and on the highest pitch of this section (Fig. 3), while the melody is distributed into several tetrachordal motivic ideas. In the second section the voice of the choir expresses the intuitions of Faust's *fanciullino* as his internal voice: it starts with a tetrachordal diatonic ascending and descending motion on a D Major chord, almost as a representation of a sort of awkward and uncertain situation. The diatonic structure is then substituted in the middle part of this

section with tetrachords formed by larger intervals. These tetrachords preserve an upwards and downwards pattern in the contour while the choir is describing God as a God of vengeance. The last pitch of this second section is the same as the last one in the first section, but the meaning of the words on it is set to are now disheartened, since God will not hear any prayers. The third section represents Faust's self-reflection: he meditates on the choir's motives and words to finally arrive to a solution on the word «Ich» (Fig. 3).

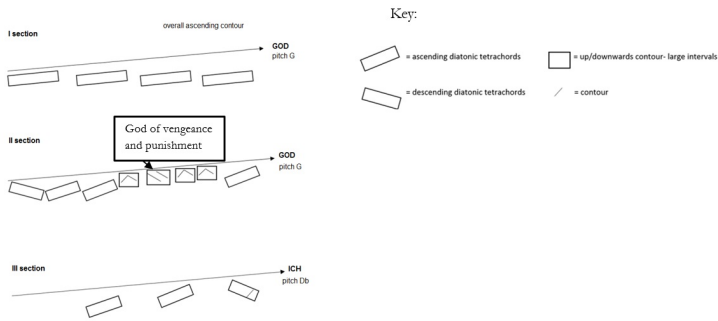

Figure 3. Contour characteristics in the three sections

From this perspective Doktor Faust's child, albeit in a different version reworked by Busoni, recalls a metaphor elucidated by Nietzsche, who in *Thus Spoke Zarathustra*⁷ considered the child as the last metamorphosis which will allow the individual to become *Übermensch* [Salter 1915, pp. 372-403]. Nietzsche describes the child as

innocence ... a self-propelled wheel, ... a sacred “Yes” ... the spirit now wills his own will, and he who had been lost to the world now conquers his own world [Nietzsche 1969, 55].

The metaphor of a child diverges in Pascoli's and Nietzsche's conception, as their approaches analyzed this symbol from two different perspectives: Pascoli's child is looking at nature through the eyes of intuition,

⁷ Like many of his contemporaries, Busoni was interested in Nietzsche's writings. For example Busoni's *Sketch for a New Aesthetic of Music* included a long passage from Nietzsche's *Beyond Good and Evil*.

Nietzsche's child is a “being” who is beyond good and evil. Busoni's child embodies both perspectives, identifying with this image the intuitive perception of the world and the awareness of a newly acquired power.

Moreover, the use of a specific combination of pitches associated to the prosody and to the plot of the scene leads one to assume that the music is following a complex path [Beaumont 1985, 325-327], which connects the final cadences of each section in a common meaningful frame. Figure 4 shows the different final cadences and the words to which the final pitches are set. In the first section, the initial dominant Bb resolves on Eb after a series of transformations through the mediant acting as a pivot note in the voice and becoming dominant in the orchestra. One of these transformations and the final cadence on the tonic are directly on the word «Gott», with the pitch g starting as a dominant of a C Major chord, but then becoming the mediant of Eb. The resolution of the initial dominant on the tonic remains within this first section, whereas Faust prolongs his sentence into the second one, while singing a chromatic dyad (o6) on the words «mir bei» [by me] and modulating to D Major (Fig. 4a).

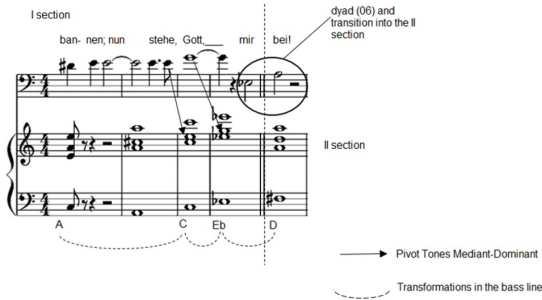

Figure 4a. Cadential sequence at the end of the first section (Church scene)

The second section starts on a D Major chord, which acts as a Dominant of G minor. This chord will resolve on the tonic while leading into the last section on the words «er hört nicht dein Gebet» [he won't hear your prayers], again on the pitch g (Fig. 4b).

The pitch g then dominates then in the third section, now on the bass line: it was used as the highest pitch in the previous two sections on

the word «Gott» as well as on the word «Gebet». In this third section, where Faust finally understands that he still has the chance to survive, the highest pitch used while looking for God becomes the lowest one: this section ends again with an incomplete sentence on an Eb Major chord. The voice concludes the verse with an upward chromatic dyad (01) on the words «ich Herr» on Db, while the orchestra plays a dyad (06) and leads into the next scene using the pitch g as the starting point for the last cadence (Fig. 4c).

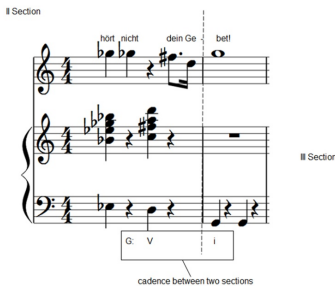

Figure 4b. Cadence between second and third section (Church scene)

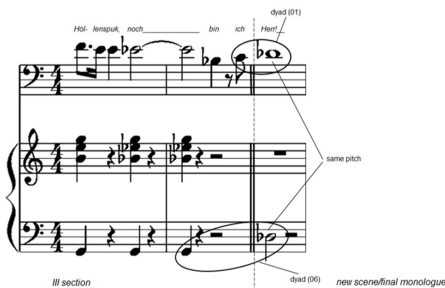

Figure 4c. From the third section into the final part of the opera leading to the final monologue

It is exactly at this point that Faust's transformation transpires, from a typical nineteenth century man who experiences dissatisfaction for his life and hopes in a God which he is unable to perceive and understand, into a conscious actor of his freedom through the intuitions of a child: in the third section God is symbolically buried in the pitch g of the bass line and evolves then into "Ich" in the final cadence.

God is dead

As Dent writes in his biography of the composer,

Busoni had been brought up in an atmosphere of Catholic piety, but he had already reacted against the doctrines of the Church when he was a young man, and although he never altogether lost a certain affection for the picturesque aspect of Catholicism, he never again returned to the Christian faith [Dent 1966, 290].

In *Sketch of a New Aesthetic of Music* (originally published in 1900) Busoni included a long passage from Nietzsche's *Beyond Good and Evil* about music. From such long passage, the following sentence is particularly interesting for *Doktor Faust's* finale: «I could imagine a music whose rarest charm should consist in its complete divorce from the Good and the Bad» [Busoni 1911, 35].

For Nietzsche the theme of the struggle between good and evil has a solution in music. In *Doktor Faust* this same theme finds an answer in the Nietzschean “Ich”. In *Ecce Homo* Nietzsche says: «But my truth is terrible: for hitherto lies have been called truth» [Nietzsche 1968, p. 782]. As described in Nietzsche's writings, Faust's final intuitions also concern the truth about the existence of good and evil. The choir invites Faust to become aware of the fact that God is the most ancient lie: a God of mercy but also of punishment and vengeance does not exist. In the last part of the final scene the death of God becomes the resurrection of a responsible man, master of his fate, whose will is now free to assert itself as “Ich” and “Herr”.

The idea of a transition from an individual in need of God's support to an individual conscious of his power is not only obvious in the text, but it permeates the entire musical structure. Using an oriented network of transformations,⁸ Figure 5a shows the interaction between voice and bass line in the final measures of each of the three sections. The transformations happening at the end of the first and last section are

⁸ The model for this kind of transformational network is clearly illustrated in Rings' book *Tonality and Transformation* [2011, 101-148].

overall inverted in the two voices. Instead the endings in the second and third section show the same distances between the two voices, as this would be an agreement on the conclusion that God won't listen to any prayers.

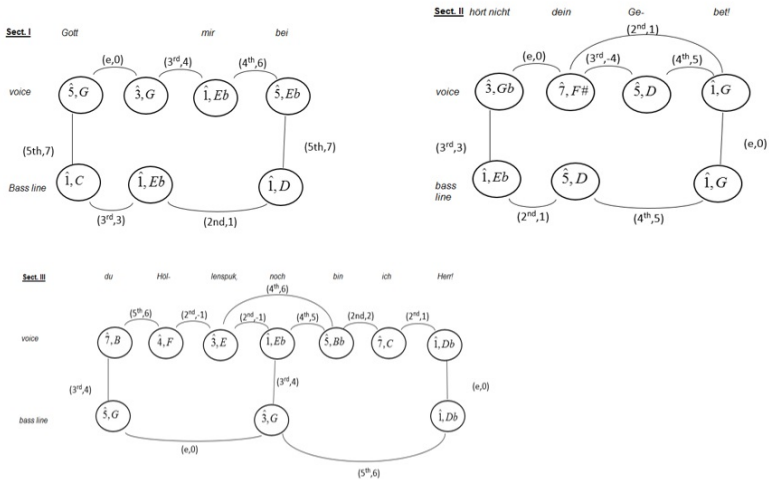

Figure 5a. Network of transformation in the three sections of the last scene composed by Busoni

Moreover, labelling each transformation with different letters, as in Figure 5b, we can clearly observe how the transformations “x”, “y” and “z” (where “z” represents the trust in God) are transferred from the upper voice in the first section to the bass/harmonic line in the last one. In the second section the “w” transformations, which could be intended as the victory of Faust's will (the chromatic steps), only happen twice, in the lower and in the upper voice, and particularly on the words «Dein (Ge-)bet». This section completely neglects the connection to Faust's «mir bei» (a “z” transformation). Instead, in the third section the “w” transformations are multiplied in the upper voice, especially in the final part: it seems to suggest a final resolution for Faust, who will rediscover his power by the end of this scene, and particularly on the last words «ich Herr».

Faust is a man who is becoming “Herr” in the perspective of D'Annunzio's

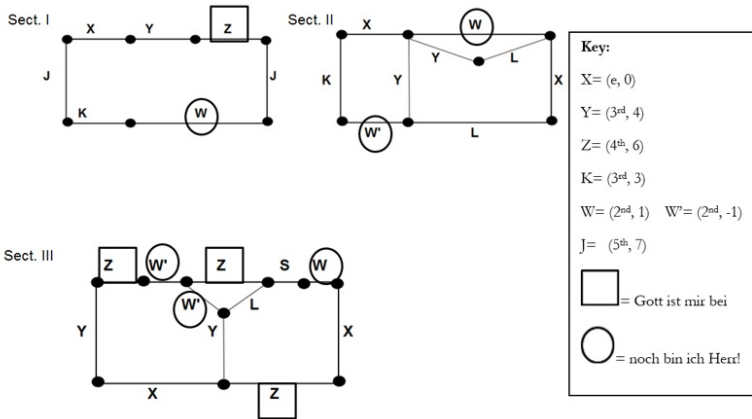

Figure 5b. Labelled network of transformations

Superuomo and goes beyond man and God, while approaching the beasts, divorcing from God and the Devil, and becoming a hero. Starting from Nietzsche's concept, Gabriele D'Annunzio had reinterpreted the original concept of the German philosopher, identifying the *Superuomo* with an aesthete who lives above the rules, who places himself above the commonly accepted moral conventions of society, and dominates reality, free from feelings of defeat [Scarano Lugnani 1976, 43]. Busoni resumed for a brief moment this feeling of superiority distinctive of the *Superuomo* as Faust, trying to fight against a cruel fate, becomes the Lord of his own destiny.

Nirvana as the realm beyond good and evil

Busoni wrote that the *Doktor Faust* libretto was «free of any philosophical intentions» [Chamness, 35].⁹ This issue can be seen more as an “intentional fallacy”:¹⁰ there is an authorial intention, but this intention will not always coincide with the interpretation that others will find in the work. Faust epitomizes the transformation in poetry and music of

⁹ Busoni's letter to Gisella Selden-Goth, May 1920.

¹⁰ William Kurtz Wimsatt and Monroe C. Beardsley define it as «a confusion between the poem and its origins» [1946].

Busoni's philosophical path, which can be regarded as a personal interpretation of concepts expressed by Pascoli, Nietzsche, and D'Annunzio. Faust's (as well as Busoni's) search was a quest for total enlightenment and for a total transformation of the heart and the mind.¹¹ Busoni wrote in *Sketch of a New Aesthetic of Music* that the ultimate aim in music is to reach the center of a musical circle, a Nirvana:

If Nirvana is the realm “beyond good and evil”, so here's a way. Up to the Porte. Up to the grid, which separates human beings and eternity or opens up, to let in the past. Beyond the gate it sounds music. Not musical art. Maybe we only need to leave the Earth, to hear it. But the grid opens only to the wanderer, who knows the road to uncloak the earthly chains [Busoni 1911, 48].

As belonging to a circle, or Mandala, the cycles symbolize the process of transformation that humans must undergo to reach Nirvana: this process proceeds from the earthly world on the outer ring to a higher level of knowledge at the center, where total enlightenment can be reached [Trainor 2001, 40].

The search for total enlightenment appears not only in Faust as a character, but also in the compositional structure of the scene. In fact, the overall structure is characterized by the rotation of some musical material in connection to the plot, which is intertwined with the transformations of short motives interrupted by rests. This pattern creates continuity through a periodical alternation of certain intervallic distances in the melodic gesture. It is possible to model the intervallic structure of the gestures in mod. 12 using a GIS¹² statement for which $\text{int}(s,t)=i$, so that “the interval from s to t ” is “ i ” [Lewin 1987, 16], and subdivide the gestures according to their intervallic space (Fig. 6).

¹¹ In Buddhism as well, an ordinary person is trapped in the endless cycle of recurring events. One is reborn, lives, and dies in endless rebirths in different categories of existence. It is only when suffering becomes unending, that an entity looks for a solution [Gomez 1991, 107].

¹² Lewin's *Generalized Interval System* consists in modeling directed measurement, distance, or motion in musical space.

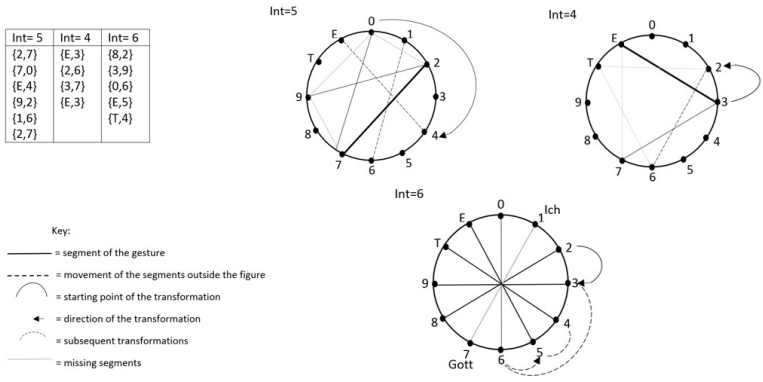

Figure 6. Representation of transformations within groups sharing the same GIS on a clock face

This scene uses three main intervallic gestures: int=4, int=5 and int=6. Modelling the succession of each type of gesture on a clock face divided into 12 chromatic pitches, it is possible to obtain a different model of motion for each of the three groups. The group with int=5 can be represented by a shape formed by the base and the diagonals of an isosceles trapezoid: the base of the shape represents the beginning and the end of the sequence, while the diagonals move on a clock face distance of +4. Instead, the group of gestures with int=4 moves the segments on a space which ideally could form an equilateral triangle with a missing side: in this group the beginning and the end of the series share again the same segment, while the other segments move on the clock face of -/+1. The same kind of small-step motion is the model of the group formed by the gestures with int=6: the first half of the series moves at first by +1 on the clock face. Then there is a large jump of +3 with the subsequent inversion of the direction with regard to the initial motion of transformation to a -1 step. It is worth while to observe that the only segment missing on this clock face would be formed by the pitches 7 and 1: these two pitches again correspond to the final pitches of each of the three sections of Faust's transition from «God is by me» and «He won't hear your prayers» (pc 7), to «I am the Lord» (pc 1).

The analysis of the structure of the ascending and descending diatonic tetrachords allows us to highlight Faust's path to immortality/Nirvana even better. Figure 7 shows a chart listing the diatonic tetrachords within the motivic gestures in order of appearance.¹³ The series of tetrachords forms a cycle, which stops before the final part of the third section: here the semitone is for the first time in the middle of a tetrachord and it appears to break a vicious cycle. This semitone in the middle of a diatonic tetrachord has an insightful significance: the future (salvation or damnation) is not above or below us, i.e. outside ourselves, but it is exactly in us, in the center and therefore in the middle of a tetrachord.

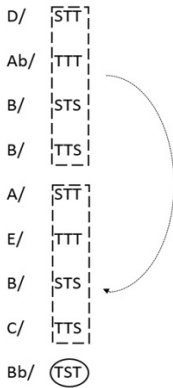

Figure 7. Sequence of diatonic tetrachords in the three sections

In the sequence of tetrachords and in the intervals of the melodic gestures the cycles aim to become the musical representation of a circle. The circle is an important symbol throughout the opera: it dominates visually and musically, in the structure, in the text, on the stage and behind it.¹⁴ The recurring events and therefore the philosophical concept of eternal recurrence could be interpreted as a fatalistic view of

¹³ This is a model of analysis used by Steven Rings in his analysis of Bach's *Fugue in E major*, Book II [2011, 151-169]. The left column shows the starting pitch of the tetrachords, the right their species such as X/STT means that a tetrachord is starting on an X pitch and will continue the sequence by semitone-tone-tone.

¹⁴ The opera closes the circle connecting the real and the unreal. Events are audible on the

life, but Nietzsche clarified that the *Übermensch* is precisely the one who is able to transcend the universal law that other beings follow blindly. For Faust the center of a tetrachord may represent Nirvana, where the chromatic step becomes the symbol of his *fanciullino*, intended as that pure intuition which will allow immortality.

The final monologue

In the last monologue Faust uses his final spell to transfer his life to the child.

Blut meines Blutes, / Gliede meines Gliedes, / Ungeweckter, / Gesitig-reiner,
/ noch ausserhalb aller Kreise / und mir in diesem / innigst verwandt, / Dir
vermach' ich mein Leben: / es schreite / von der erdeingebissenen Wurzel /
meiner scheidenden Zeit / in die luftig knospende Blüte / deines
werdenden Seins. / So wirk' ich weiter in dir, / und du zeuge fort / und
grabe tiefer und tiefer / die Spur meines Wesens / bis and das Ende des
Triebes. / Was ich verbaute, richte du grade, / was ich versäumte, schöpfe
du nach, / so stell' ich mich / über die Regel, umfass in Einem / die Epochen
und vermenge mich / den letzten Geschlechtern: Ich, Faust, / ein ewiger
Wille! [Busoni 1926, 314-317].¹⁵

Faust falls dead, and a naked youth arises from the circle holding a blossoming branch in his right hand and stepping forth into the night: the circle allows the continuation of life.

This final monologue contains a profound thought about life and

stage but not visible and viceversa, "Pax" opens and closes the opera, and the stage was used by Busoni in a way that included the audience's imagination. The opera starts and finishes at Easter's Sunday, closing a cycle. Also the initial prologue mentions circles. In the plot, at the beginning of the opera Faust has been lured into a trap by Mephistopheles because he was out of the circle when the last demon suddenly appeared [Beaumont 1985, 308]. At the end of the opera Faust is using the circle to protect his child.

¹⁵ Blood of my blood, / limb of my limb, / not yet awakened, / pure spirit, / out of each circle / and so close to me, / to you I tie my life: / from the deepest root of my existence / in the new flower / that blooms in you. / I will perpetuate myself in you / and you will dig deeper the groove / of my life until its end. / Straighten what I deformed, / create what I have neglected. / I rise myself above the rules, / embracing all ages in one / and finally I will join to the last generation: / I, Faust, / the eternal will.

death: Faust declares that he is conscious of being free from any good or bad divine existence, as well as from this quarrel as to the afterlife which has been handed down from generation to generation. As *Übermensch*, Faust is the one who is willing to risk all not only for the sake of his own salvation, but also for the enhancement of human beings. Busoni characterizes *Doktor Faust* as a hybridization of his own thoughts: Faust's depiction may not be intentional, but in his main character Busoni summed up all the qualities of the European philosophies of his time mixed with Buddhism.¹⁶ Faust affirms his will, while living further through his son, who is becoming the poet and hero who defeats the beast.

Faust's monologue represents his rebirth as a "Mensch". In his monologue Faust acknowledges his transcendent power, the Nietzschean will to power believed to be the main driving force in humans: achievement, the striving to reach the highest possible position in life. *Doktor Faust*'s attainment of immortality does not pray for divine redemption and wins out over everything. In Busoni's opera, Faust is neither redeemed nor damned and becomes aware that death is nothing but the means that leads to rebirth.

References

- Beaumont A. (1985), *Busoni the Composer*, Indiana University Press, Bloomington.
- Busoni F. (1911), *Sketch of a New Aesthetic of Music*, G. Schirmer. New York (or. ed. *Entwurf einer neuen Aesthetik der Tonkunst*, Insel-Verlag, Leipzig 1900).
- Busoni F. (1926), *Doktor Faust*, Breitkopf & Härtel, Wiesbaden (or. ed. Breitkopf und Härtel, Leipzig 1925).
- Busoni F. (1965), *The Essence of Music: and Other Papers*, Dover Publications, New York.
- Busoni F. (1984), *Doktor Faust*, Breitkopf & Härtel, Wiesbaden.
- Chamness N. O. (2001), *The Libretto as Literature: Doktor Faust by Ferruccio*

¹⁶ Busoni's book collection included H. Kern's *Buddhism in India* (1901), *Die Reden Gothama Buddhos* translated by Neumann (1922), *Chinese Ghost and Love Stories* translated by Martin Buber. He also uses some of the concepts he embodied in Faust in his book *The Essence of Music* [Busoni 1965].

Busoni, Peter Lang, New York.

Dent E. J. (1966), *Ferruccio Busoni: A Biography*, Clarendon Press, Oxford.

Gomez L. O. (1991), *Purifying Gold: The Metaphor of Effort and Intuition in Buddhist Thought and Practice*, in P. N. Gregory (ed.), *Sudden and Gradual. Approaches to Enlightenment in Chinese Thought*, Motilal Banarsidass Publishers Private Limited, Delhi.

Lewin D. (1987), *Generalized Musical Intervals and Transformations*, Yale University Press, New Haven.

Ley R. (1938), *Ferruccio Busoni: Letters to His Wife*, Edward Arnold & Co., London.

Lugnani Scarano E. (1976), *D'Annunzio*, Laterza, Bari.

Nietzsche F. (1968), *Basic Writings of Nietzsche*, ed. by W. A. Kaufmann, A Modern Library, New York.

Nietzsche F. (1969), *Thus Spoke Zarathustra. A Book for All and No One*, Penguin Books, London (or. ed. *Also sprach Zarathustra. Ein Buch für Alle und Keinen*, E. Schmeitzner, Chemnitz 1883).

Pascoli G. (1982), *Il fanciullino*, ed. by G. Agamben, Feltrinelli, Milano (or. ed. *Pensieri d'arte poetica, «Il Marzocco»*, Franceschini, Firenze 1897).

Rings S. (2011), *Tonality and Transformation*, Oxford University Press, New York.

Rubiner L. (2013), *Der Mensch in der Mitte*, Hard Press, Lenox (or. ed. *Verlag der Wochenschrift Die Aktion (Franz Pfemfert)*, Berlin-Wilmersdorf, 1917).

Salter W. M. (1915), *Nietzsche's Moral Aim and Will to Power*, «International Journal of Ethics», 25/3, pp. 372-403.

Trainor K. (2001), *Buddhism. The Illustrated Guide*, Oxford University Press, Oxford-New York.

Wimsatt W. K.–Beardsley M. C. (1946), *The Intentional Fallacy*, «The Sewanee Review», 54/3, pp. 468-488.